

# Questionnaire

## System TIVAR® Engineering Linings

Company: \_\_\_\_\_

Contact: \_\_\_\_\_

Telephone: \_\_\_\_\_

Fax: \_\_\_\_\_

E-mail: \_\_\_\_\_

The following object is intended to be lined with System TIVAR® Engineering.  
Please submit an offer without obligation.

Malfunctions occur through:  caking  bridging  
 freezing  corrosion  
 other \_\_\_\_\_

Type of bulk material: \_\_\_\_\_

Particle size: max. \_\_\_\_\_ mm min. \_\_\_\_\_ mm

Particle shape: round, crystalline, lignitic \_\_\_\_\_

Moisture content: \_\_\_\_\_ %

Density: \_\_\_\_\_

Bulk material temperature: max. \_\_\_\_\_ °C min. \_\_\_\_\_ °C

Throughput: \_\_\_\_\_ t/h

Operating time: \_\_\_\_\_ h/day

Construction material:  steel  
 concrete  
 aluminium  
 other \_\_\_\_\_

Wall thickness: \_\_\_\_\_ mm

How is the system charged?  
e.g. conveyor belt, truck, railcar \_\_\_\_\_

Charging:  continuously  discontinuously

How is the system discharged?  
e.g. vibrating chute, apron feeder \_\_\_\_\_

Discharging:  continuously  discontinuously

Will there be a material buffer  
in the bunker:  yes  no

Height of material buffer: \_\_\_\_\_ m

Does impact abrasion occur:  yes  no

Is the system located:  inside  outside

Is there a risk of dust explosions:  yes  no

### Conditions of installations:

Lift available:  yes  no

Physical dimensions: \_\_\_\_\_

380V/63A available:  yes  no

Special regulations:  yes  no

Locker room available:  yes  no

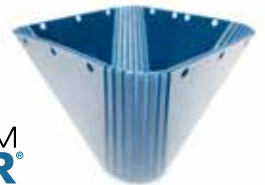

If drawings or sketches of this project are not available, please complete the following questionnaire.

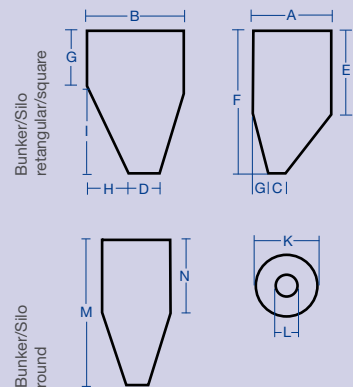

A = \_\_\_\_\_ H = \_\_\_\_\_  
 B = \_\_\_\_\_ I = \_\_\_\_\_  
 C = \_\_\_\_\_ K = \_\_\_\_\_  
 D = \_\_\_\_\_ L = \_\_\_\_\_  
 E = \_\_\_\_\_ M = \_\_\_\_\_  
 F = \_\_\_\_\_ N = \_\_\_\_\_  
 G = \_\_\_\_\_

Troughs - chutes  
 width = \_\_\_\_\_ mm  
 length = \_\_\_\_\_ mm  
 slope = \_\_\_\_\_ mm

Is impact protection available  yes  no

Belt speed = \_\_\_\_\_